



GTC - 100



GTC - 100

GTC is multipurpose drilling rig designed for professional and frequent use. Machine is easy for handling and operating. Complete system is hydraulic powered with Briggs and Stratton engine. Because it's small weight it can be transported in van.

AREA OF USAGE:

- ➔ Water wells
- ➔ Geothermal drilling
- ➔ Geotechnical drilling
- ➔ Sampling
- ➔ DTH drilling

GTC offers additional upgrades such as: break clamp, winch with extension and double speed gearbox. Also, stronger engine models can be installed. Therefore increasing machine power and performance.



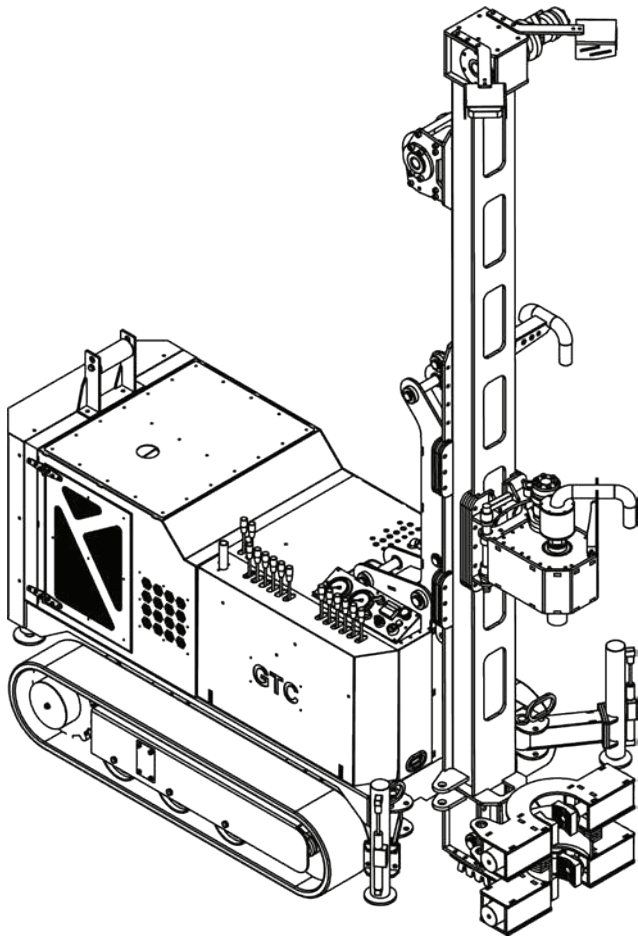

| SPECIFICATIONS | GTC - 100 |
|-----------------------|-------------|
| Rotary head torque | 1400-2800nm |
| Rotary head RPM | 30-80 |
| Max pull up | 2500kg |
| Max pull down | 1300kg |
| Water swivel head | Yes |
| Pipe feed | 2m |
| Max drilling depth | 80-100m |
| Max drilling diameter | 300mm |
| Power supply | Diesel |
| Engine power | 25hp Kubota |
| Mast sliding | 500mm |
| Clamping head passage | 170mm |

RIGHT SIDE - NEUTRAL POSITION

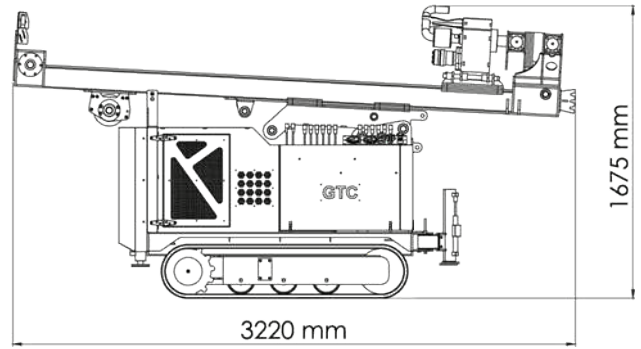

REAR VIEW

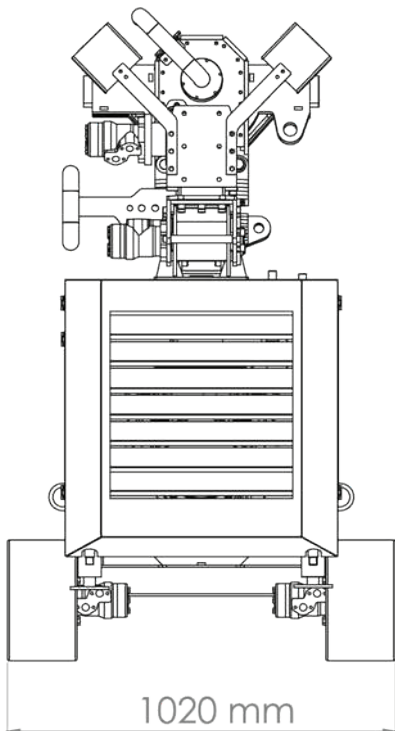

RIGHT SIDE - DRILLING POSITION

