



8 and 11 Blade SPA Cutting Units Greensmaster[®] 3000 Series Traction Units

Model No. 04450—220000001 and Up

Model No. 04468—220000001 and Up

Parts Catalog

Ordering Replacement Parts

To order replacement parts, please supply: the part number, the quantity, and the description of each part desired.

Understanding Reference Numbers

Each identified part in an illustration has a reference number. The reference number for a part also appears in the parts list, along with other information about the part.

This catalog uses two special reference number formats, one to indicate parts in a service assembly and another to indicate the quantity of a given part in an illustration.

Service Assembly Reference Numbers

Parts in service assemblies have reference numbers in the form **a:b**. The **a** represents the reference number of the entire service assembly and the **b** represents a sequential number unique to each part within the service assembly.

For example, a wheel assembly might be identified by reference number **6**, the tire by **6:1**, the valve by **6:2**, and the wheel by **6:3**. When you order the assembly identified by reference number **6**, you receive all parts identified by reference numbers **6:1**, **6:2**, and **6:3**. However, you may also order any part individually.

Reference numbers of this type appear in illustrations and in part lists.

Reference Numbers Indicating Quantity

In an illustration, if a reference number indicates more than one part, the reference number has the form **nX y**. The **n** represents the quantity of the part, the **X** is the multiplication symbol, and the **y** represents the reference number.

For example, in an illustration, the reference number **2X 37** means that two of the parts identified by reference number **37** are indicated.

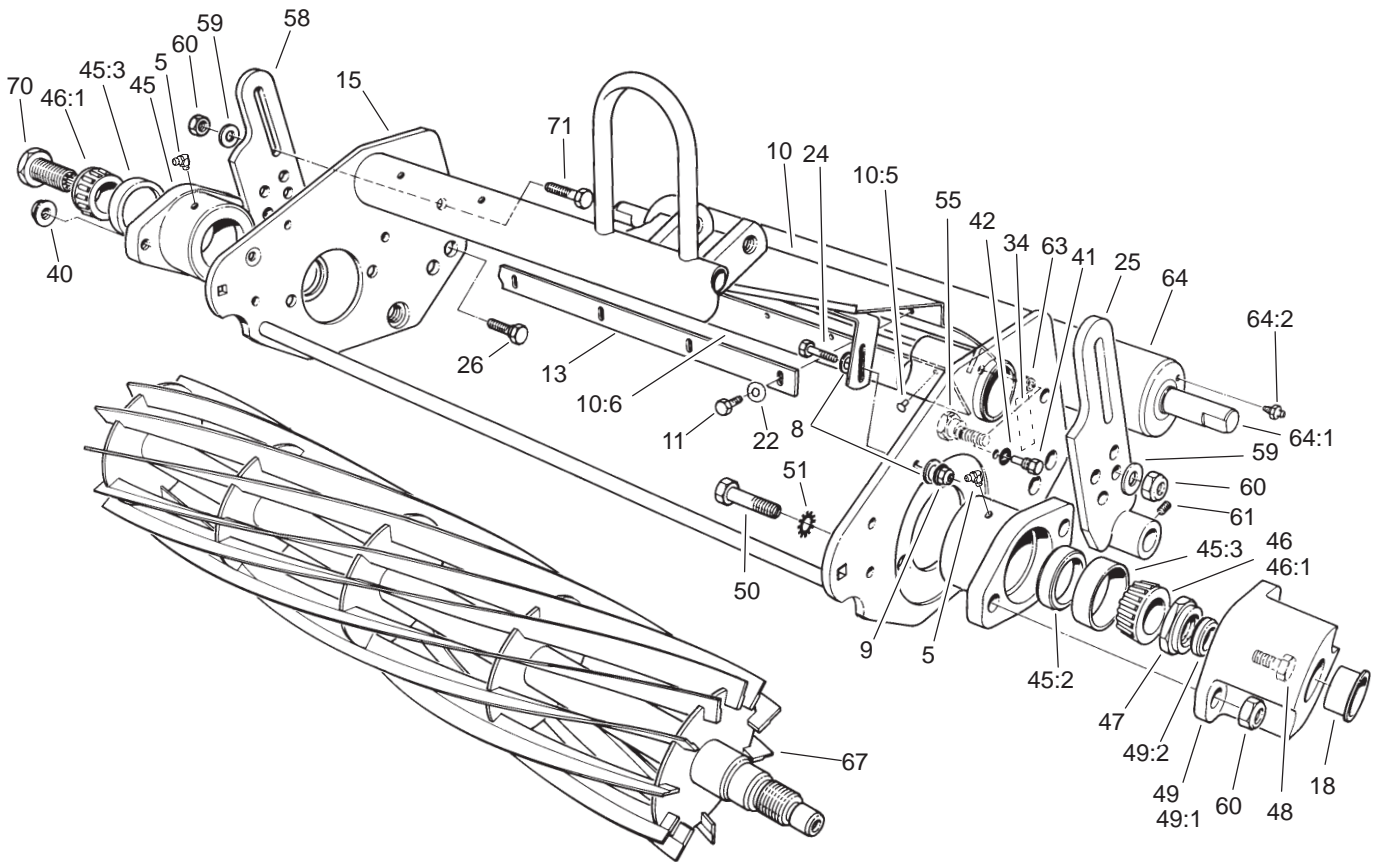

Sheet No.:2
T-3809

Reel and Frame Assembly

Ref. No.	Part No.	Qty.	Description
5	302-11	2	Fitting-Lube, 45°
8	3256-22	4	Washer-Flat
9	3296-42	2	Nut-Lock, NI
10	57-5200	1	Grass Shield ASM
10:5	3295-46	13	Rivet
10:6	57-5210	1	Shield Flap
11	104-2065	5	Screw-HWH
13	36-7260	1	Bar-Off, Cut
15	70-1200-01	1	Frame-Reel
18	12-0460	1	Caplug
22	3256-14	5	Washer-Flat
24	321-5	2	Screw-HH
25	77-1080	1	Adjust-HOC, LH
26	52-3110	1	Bolt-HOC Shoulder, RH
34	77-0490	1	Decal-Bolt, Eccentric
40	32128-36	2	Nut-HF
41	57-9910	2	Pivot Screw
42	3254-6	2	Washer-Lock, Internal
45	104-3399	2	Bearing Housing ASM
45:2	104-3388	1	Seal-Grease
45:3	254-72	1	Bearing-Cup, Tapered
46		2	Bearing W/Grease
46:1	254-94	1	Bearing-Cone, Taper
47	3296-60	1	Nut-Lock, NI
48	323-2	1	Screw-HH

Ref. No.	Part No.	Qty.	Description
49		1	End Cap ASM
49:1	10-5080-01	1	Cap-End
49:2	253-61	1	Seal-Oil
50	57-3210	4	Screw
51	3255-9	4	Washer-Lock/Ext
55	52-3100	1	Bolt-HOC Eccentric, LH
58	77-1060	1	Adjust-HOC, RH
59	3256-24	4	Washer-Flat
60	3296-39	6	Nut-Lock, NI
61	3246-2	2	Setscrew-HSH
63	237-84	2	Grommet
64	52-3120	1	Roller ASM
64:1	21-6430	2	Bearing
64:2	302-5	2	Fitting-Grease
67	12-3599	1	8 Blade Reel ASM (only on: 04468)
67	12-2789	1	11 Blade Reel ASM (only on: 04450)
70	93-1394	1	Nut-Spline
71	323-7	2	Screw-HH

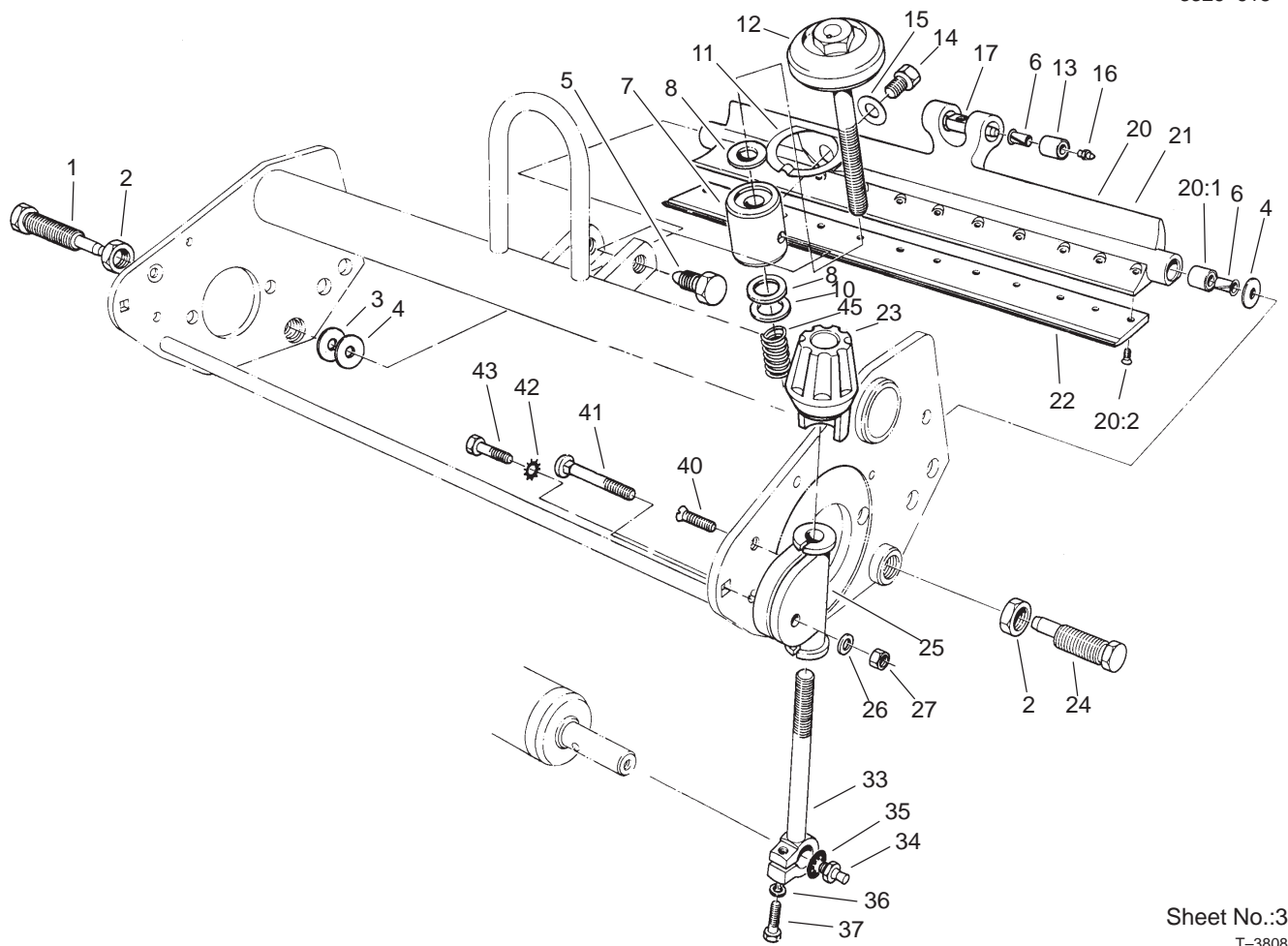

Sheet No.:3

T-3808

Bed Bar Assembly

Ref. No.	Part No.	Qty.	Description
1	52-2930	1	Bolt-Shoulder
2	3220-6	2	Nut-Jam
3	52-2860	1	Washer
4	52-2900	2	Washer
5	66-7240	2	Screw-Pivot
6	52-2890	4	Bushing-Nylon
7	77-0330	1	Housing-Pivot
8	77-0350	2	Washer-Thrust, Nylon
10	257-5	1	Washer-Thrust
11	66-7220	1	Arm-Spring
12	77-0300-01	1	Handle ASM
13	62-5510	2	Bushing-Rubber
14	324-25	1	Screw-HH
15	3256-25	1	Washer-Flat
16	302-18	1	Fitting-Grease
17	57-5260	1	Pivot-Bedbar
20		1	Bedbar/Bushing ASM
20:1	63-9510	2	Bushing
20:2	57-4910	13	Screw
21	57-4940-01	1	Bedbar
22	93-4262	1	Bedknife-Microcut
22	93-4263	1	Bedknife-Tournament
22	93-4264	1	Bedknife-Lowcut
22	94-6392	1	Bedknife-Highcut
23	65-8600	2	Knob-Adjustment, Height

Ref. No.	Part No.	Qty.	Description
24	52-2910	1	Bolt-Eccentric
25	10-5060	2	Bracket-HOC
26	3256-23	2	Washer-Flat
27	3296-29	2	Nut-Lock, NI
33	10-5010	2	Screw-Adjustment, Roller
34	94-2958	2	Stud-Ball
35	3254-6	2	Washer-Lock, Internal
36	3253-3	2	Washer-Lock
37	321-4	2	Screw-HH
40	32108-20	2	Screw
41	3-7253	2	Bolt-Carriage
42	3255-8	2	Washer-Lock/Ext
43	322-5	2	Screw-HH
45	66-7230	1	Spring-Compression

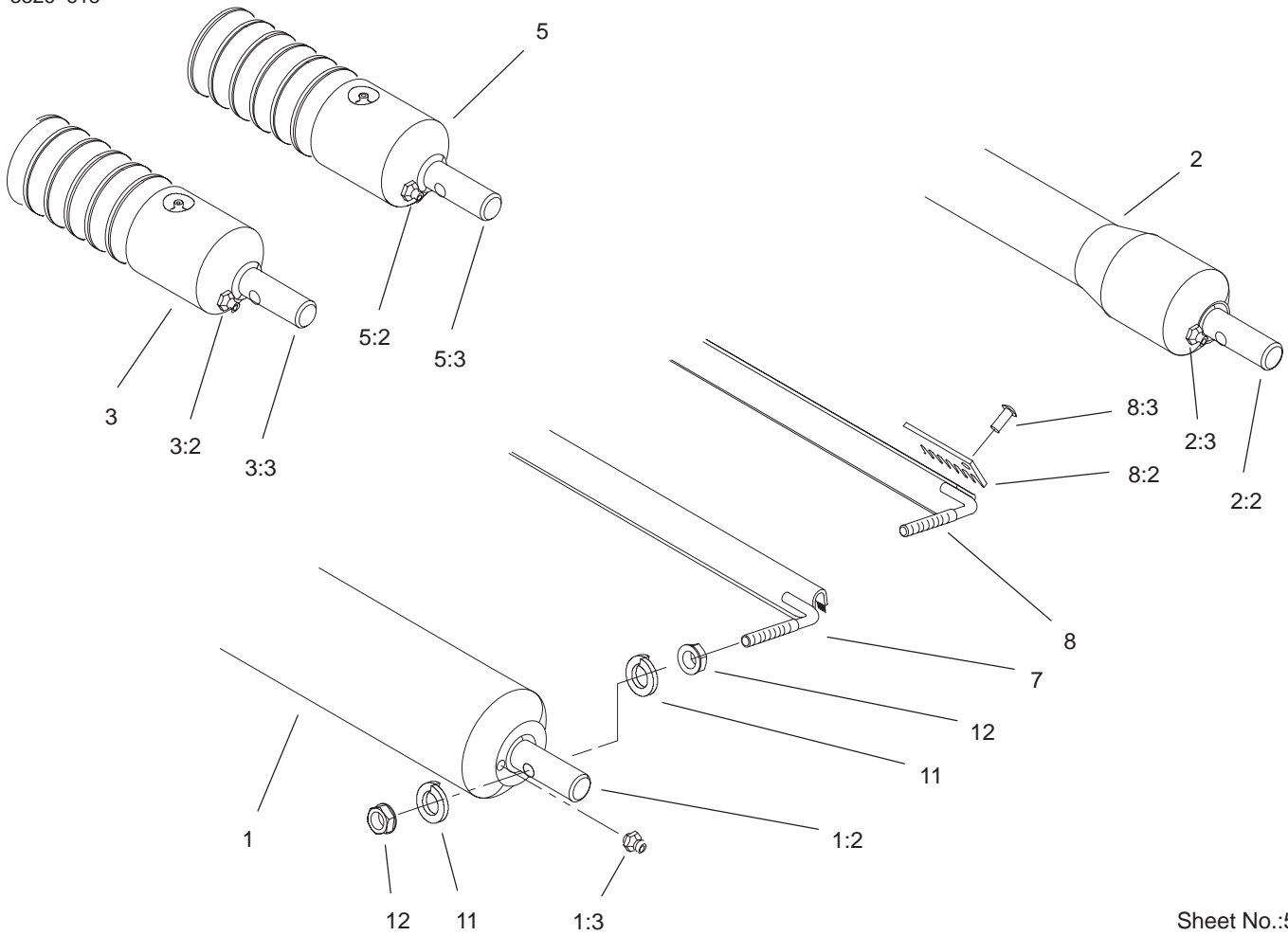

Sheet No.:5

Roller and Scraper Options

Ref. No.	Part No.	Qty.	Description
1	52-3170	1	Full Front Roller ASM
1:2	52-3180	2	Bearing-Roller, Front
1:3	302-5	2	Fitting-Grease
2	52-3590	1	Swaged Roller ASM
2:2	52-3180	2	Bearing-Roller, Front
2:3	302-5	2	Fitting-Grease
3	71-1550	1	Wiehle Roller ASM
3:2	302-5	2	Fitting-Grease
3:3	52-3180	2	Bearing-Roller, Front
5	88-6790	1	Wiehle Roller ASM
5:2	302-5	2	Fitting-Grease
5:3	52-3180	2	Bearing-Roller, Front
7	33-1000	1	Scraper Brush ASM
8	11-0070	1	Scraper Comb ASM
8:2	8-2530	1	Comb
8:3	3295-2	11	Rivet-Semi
11	3254-8	4	Washer-Lock
12	3219-1	4	Nut-Hex

Ref. No.	Part No.	Qty.	Description