

## PERFORMANCE

WORKING HEIGHT	40.20 m
HORIZONTAL OUTREACH	14.80 m
UP AND OVER CLEARANCE	-
WINCH CAPACITY	500 Kg
MOVABLE JIB	180°
CAGE ROTATION	-
TURRET ROTATION	440°
GRADEABILITY	30%
SLOPE ANGLE ( $\alpha$ )	12.5° - 23°
TRAVEL SPEED	1.0-2.0 Km/h

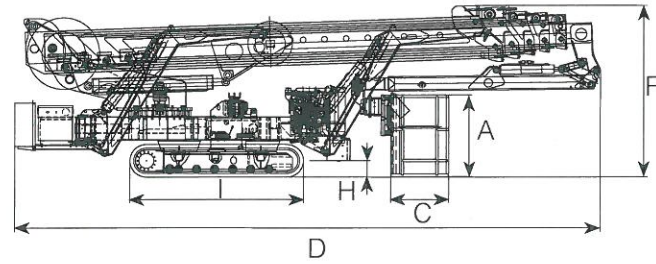

## MEASURES

CAGE HEIGHT (A)	-
CAGE LENGTH (B)	-
CAGE WIDTH (C)	-
LENGTH (D)	8.10 m
LENGTH WITHOUT CAGE (E)	-
HEIGHT (TRAVELLING POSITION) (F)	2.20 m
WIDTH, MIN (G)	1.42 m
WIDTH, MAX (G')	-
GROUND CLEARANCE (H)	0.25 m
GROUND CLEARANCE MAX (H')	-
TRACK (L x W) (I)	2.42 x 0.32 m
LENGTH OUTRIGGER STANDARD (J)	6.40 m
WIDTH OUTRIGGER STANDARD (K)	5.20 m
LENGTH OUTRIGGER NARROW (L)	7.60 m
WIDTH OUTRIGGER NARROW (M)	3.80 m
WIDTH OUTRIGGER MEDIUM (N)	4.50 m
OUTRIGGER PLATE ( $\phi$ )	0.20 m

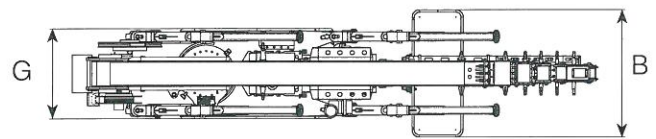

## WEIGHT

TOTAL WEIGHT	8800 Kg
TRAVEL CONFIGURATION PRESSURE	7.06 kN/m <sup>2</sup>
WORK CONFIGURATION PRESSURE	8.31 kN/m <sup>2</sup>
MAX OUTRIGGER FORCE	54.94 kN

## POWER SOURCES

STANDARD Diesel Engine	42 kW
STANDARD Electric Motor	380V - 7.5 kW
OPTIONAL Lithium Battery	48V - 200 Ah
FUEL TANK CAPACITY Diesel Engine	50 l
OIL TANK CAPACITY	140 l

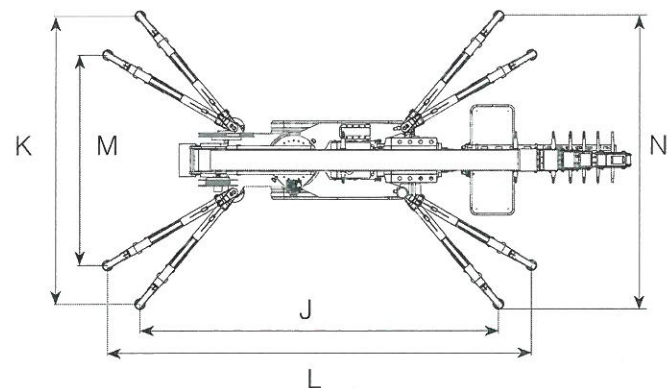

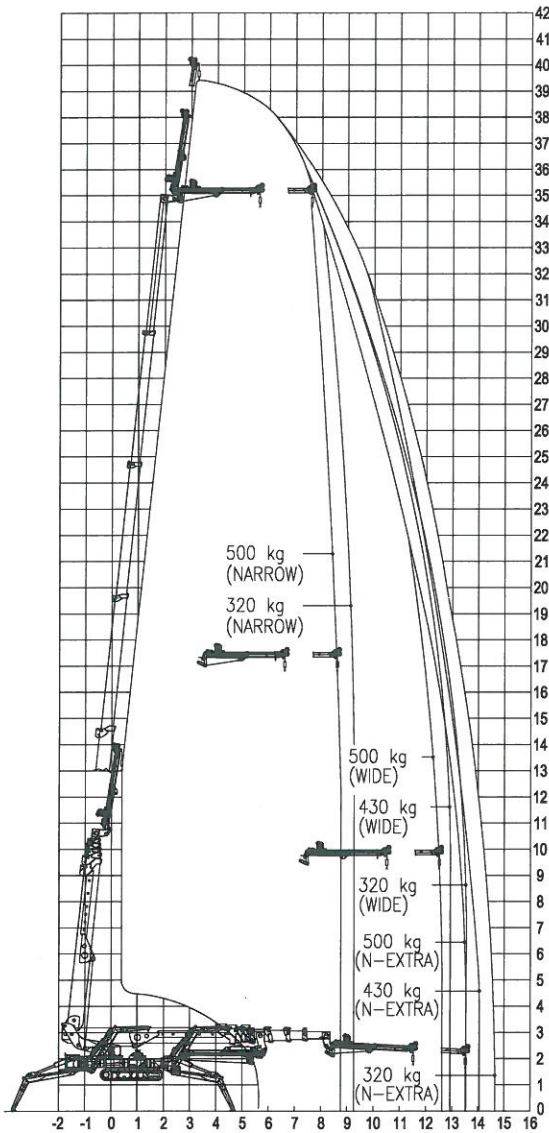

## CHASSIS

- Powerful track drive with hydraulic braking system
- Precise manoeuvring over sensitive radio control
- Rubber tracks with specially arranged profile providing optimum grip

## STABILISATION

- Variable outrigger system with one side or both sides narrow or wide setup option

## BOOM SYSTEM

- Telescopic boom + jib
- Articulated Jib 180°
- Turnable basket 180°
- Electric proportional (Danfoss) and radio controls
- Electric cage self levelling system
- Turret rotation with slewing ring

## POWER SOURCES

- 380V electric motor
- 42 kW Hatz diesel engine with electronically regulated engine control
- Start/ Stop device for the engine in the cage

## PRODUCTIVITY, SAFETY & QUALITY

- 110V (US) / 230V (EU) power socket in the cage
- High quality paint in RAL 9003 & RAL 2001
- Electric pump for emergency lowering
- Lock valves on hydraulic cylinders
- Relief valves protecting the hydraulic system from too high pressures
- Protective covers for all components
- Hour meter

## OPTIONS

- Battery drive (lithium) 48V 200 Ah (R420HY)
- Outrigger self levelling system
- Outrigger pads
- Non marking rubber tracks
- Custom paintwork
- Air/ water plug