



# EPT20-15ET2

## Electric Pallet Truck 1.5t

- Perfect Upgrade of Reliability and Easy-maintenance



**ALEXANDROS SPATHARAS COMPANY**  
**CRANES - MACHINERY - SPARE PARTS**  
41, Iasonidou Str.  
GR-56334 Thessaloniki, GREECE  
N. Kordelio - Eleftheria  
Tel: +30 2310 709155  
Fax: +30 2310 709989  
[www.spatharas.eu](http://www.spatharas.eu)

## FEATURE

### ■ Patented Design:

Ergonomic tiller bounded with key switch, BDI and troubleshooting indicator enhances easy and accurate operation.



### ■ External Control System:

Patent designed external control system not only protects controller in place but also provides easy access for maintenance.

### ■ Optimized Harness Layout:

Optimized wire harness layout lowers twist failure rate.

### ■ Front Detachable Battery Cover:

Innovative Design, Easy for Battery Replacement.

### ■ Emergency Switch:

Upgraded emergency switch ensures safety.

### ■ Cover for Driving Wheel:

Strong cover for driving wheel ensures the safety of the operator.

### ■ Charger:

Upper-installed Charger, Better Heat-Exhausting, Higher Charging Efficiency



# Electric Pallet Truck 1.5t EPT20-15ET2

Distinguishing mark			
1.1	Manufacturer		EP
1.2	Model designation		EPT20-15ET2
1.3	Drive unit		Electric
1.4	Operator type		pedestrian
1.5	rated capacity	Q	kg 1500
1.6	Load center distance	c	mm 600
1.8	Load distance	x	mm 889/946
1.9	Wheelbase	y	mm 1261/1205
Weight			
2.1	Service weight (include battery)		kg 195
2.2	Axle loading, laden driving side/loading side		kg 565/1130
2.3	Axle loading, unladen driving side/loading side		kg 155/40
Types,Chassis			
3.1	Tyre type driving wheels/loading wheels		PU/ PU
3.2	Tyre size, driving wheels (diameter×width)	mm	Φ210×70
3.3	Tyre size, loading wheels (diameter×width)	mm	2x Φ78×60 (Φ78×88)
3.4	Tyre size, caster wheels (diameter×width)	mm	
3.5	Wheels, number driving, caster/loading (x=drive wheels)	mm	1x /4 (1x /2)
3.6	Track width, front,driving side	b <sub>10</sub>	mm
3.7	Track width,rear,loading side	b <sub>11</sub>	mm 410 (535)
Dimensions			
4.4	Lift height	h <sub>3</sub>	mm 115
4.9	Height drawbar in driving position min./max.	h <sub>14</sub>	mm 790/1225
4.15	Lowered height	h <sub>13</sub>	mm 80
4.19	Overall length	l <sub>1</sub>	mm 1638
4.20	Length to face of forks	l <sub>2</sub>	mm 488
4.21	Overall width	b <sub>1</sub> / b <sub>2</sub>	mm 568 (685)
4.22	Fork dimensions	s/ e/ l	mm 50/150/1150
4.25	Distance between fork-arms	b <sub>5</sub>	mm 560 (685)
4.32	Ground clearance, center of wheelbase	m <sub>2</sub>	mm 30
4.34.1	Aisle width for pallets 1000 × 1200 crossways	Ast	mm 1739
4.34.2	Aisle width for pallets 800 × 1200 lengthways	Ast	mm 1939
4.35	Turning radius	Wa	mm 1485
Performance data			
5.1	Travel speed, laden/ unladen	km/ h	km/h 4/4.5
5.2	Lifting speed, laden/ unladen		m/ s 0.029/0.038
5.3	Lowering speed, laden/ unladen		m/ s 0.046/0.033
5.8	Max. gradeability, laden/unladen		2/6
5.10	Service brake type		Electromagnetic
Electric-engine			
6.1	Drive motor rating S2 60 min	kW	0.65
6.2	Lift motor rating at S3 15%	kW	0.84
6.3	The maximum allowed size battery	mm	
6.4	Battery voltage/nominal capacity K20		24/65
6.5	Battery weight	kg	22.5x2
Addition data			
8.1	Type of drive control		DC
10.5	Steering type		Mechanical
10.7	Sound pressure level at the driver's ear		74

1.The parameters in the table are of the standard model. For more information, please contact us.  
2.The parameters are subject to change without notice.

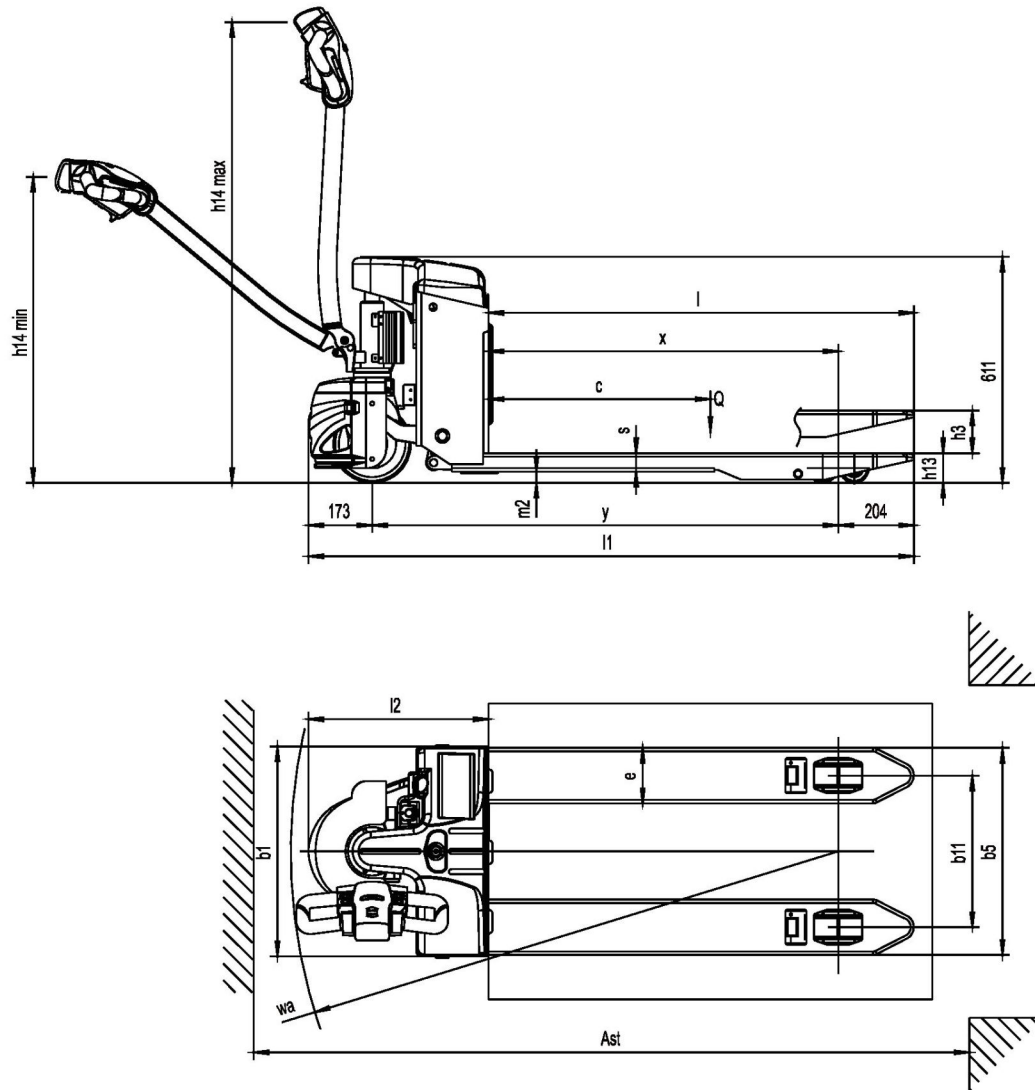

## Option

Options	EPT20-15ET2
Fork length	● 800/915/1000/1070/1100/1300/1400mm
Fork width	● 520/600mm
Single load wheel	●
Driving wheel	● PU wheel with Pattern
Battery capacity	● 85AH
Backrest height	● 1220mm (48in)/1520mm (60in)