



JLG[®]
www.jlg.com.au

TOUCAN Specifications

	Toucan 800	Toucan 1010	Toucan 1210
Dimensional Data*			
Working Height	8 m	10.10 m	12 m
Stowed Height	1.99 m	1.99 m	1.99 m
Width	0.99 m	0.99 m	1.2 m
Length	1.9 m	2.89 m	3.85 m
Outreach with standard or (large) or [rotation platform]	2.2 m (2.5 m)	3.12 m (3.43 m)	5 m [5.22 m]
Weight	1950 kg	3300 kg	5300 kg
Standard platform dimension or (large platform)	0.7 x 0.9 m (1.01 x 0.9 m)	0.7 x 0.9 m (1.01 x 0.9 m)	0.7 x 1.1 m
Performance Data			
Work platform capacity or (large platform)	200 kg (200 kg)	200 kg	200 kg
Stowed speed	0 - 4 km/h	0 - 4 km/h	0 - 3.5 km/h
Gradeability	20%	20%	20%
Slewing	360°	360°	360°
Max. wind speed for outdoor use	12.5 m/s	12.5 m/s	12.5 m/s
Turning radius inside/outside	1.05 m/2.4 m	0 m/1.75 m	1.53 m/3.20 m

* Certain weights and dimensions may vary due to options and to compliance with country standards.

The JLG "2 & 5" Warranty

JLG Industries, Inc. backs our products with our exclusive "2 & 5" Warranty. We provide coverage on all products for two (2) full years, and cover all specified major structural components for five (5) years. Due to continuous product improvements, we reserve the right to make specification and/or equipment changes without prior notification.

This machine meets or exceeds applicable Australian Standards AS1418.10 manufactured for intended applications.

lift-market.com
UŻYWANE PODESTY RUCHOME
office@lift-market.com

JLG[®]

www.jlg.com.au

JLG Industries (Australia)
ARBN 056 685 897 ABN 42 056 685 897
11 Bolwarra Road (PO Box 5519)
Port Macquarie NSW 2444 Australia

Head Office (02) 6581 1111
NSW Office (02) 8718 6300 VIC Office (03) 9545 6303
QLD Office (07) 3272 9988 WA Office (08) 9356 9811
Specifications may vary for units supplied to Australian Standards

Printed in AUSTRALIA
FORM NO.: ES-0603-5000
IMG0032JLG imagri.com.au

TOUCAN
WORKING PLATFORMS



- TOUCAN 800
- TOUCAN 1010
- TOUCAN 1210

JLG[®]
www.jlg.com.au

TOUCAN

WORKING PLATFORMS



TOUCAN 800

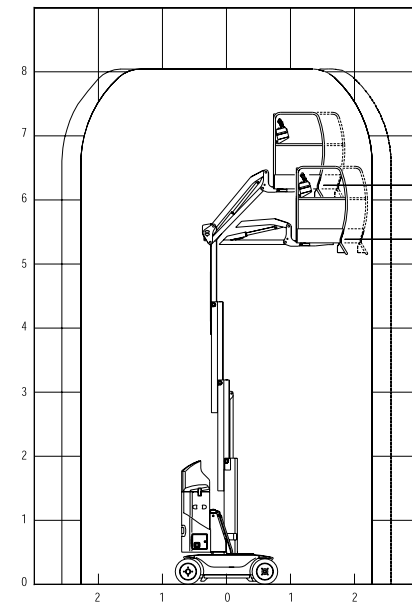

TOUCAN 1010

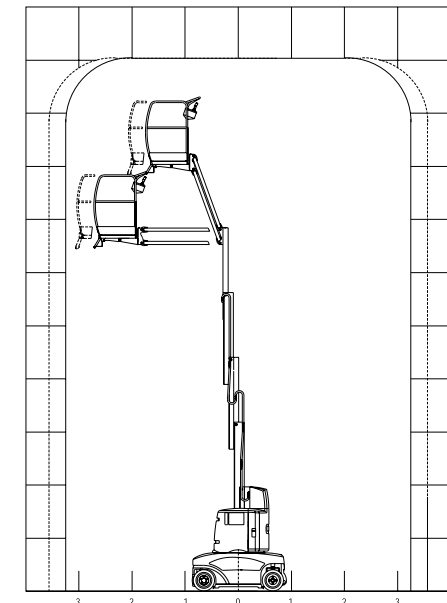

TOUCAN 1210

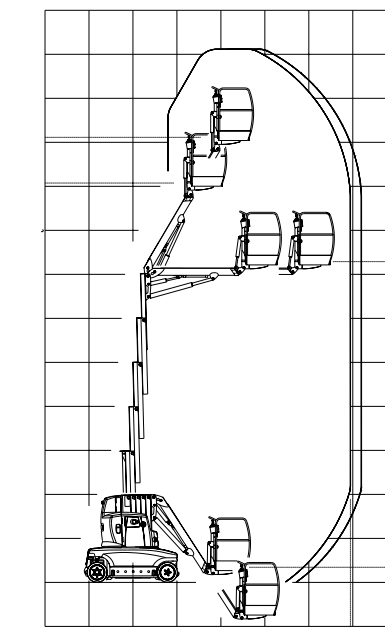

TOUCAN 800

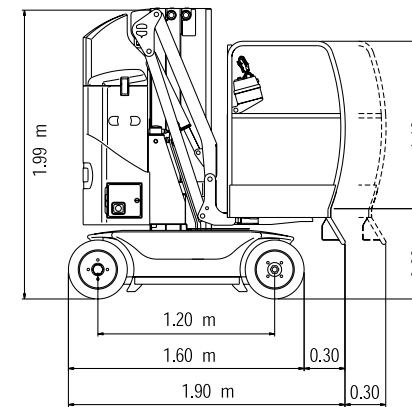

TOUCAN 1010

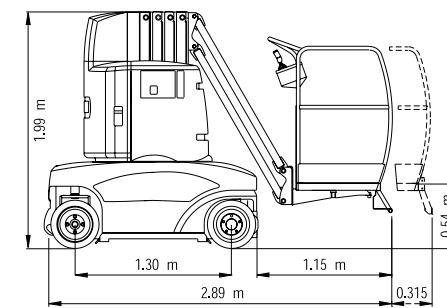

TOUCAN 1210

