



REMAV LA1200

Lightweight Separator



With the REMAV leight-weight Seperator LA1200 or LA1400 built after BEYER system you transform heavily contaminated building rubble or gravel in few seconds into a recyclable good.

It separates the lightweight materials from the rubble such as plastic, Styrofoam, and lightweight concrete or wood from the heavy particles of stone or concrete. Also chips from stones can be cleaned.

Increasing production by better quality!



The light material separator can be integrated easily into any existing recycling equipment.

Its benefits:



- Low operating costs
- Direct further processing
- Reduced disposal costs
- Minimal space needed
- Low maintenance

Available with pre-screening for particles less than 8 mm.

Visit us at:

www.remav.de

Technical Details

Screening performance LA1400:	40 - 50 m ³ /h
Screening performance LA1200:	30 - 40 m ³ /h
Feed height:	2,7 m
Installed power:	7 kW
Water Capacity:	4 - 5 cbm
Tare:	4,1 to

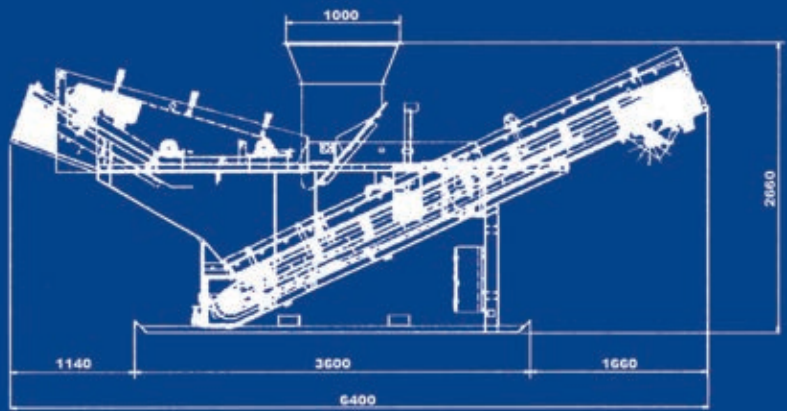

Brush Strap

Depending on the material optionally with steel spring tines to carry out the lightweight materials



Funnel

Easy loading by conveyor belt



Heavy material belt

With grooves for the return of the water and discharge of heavy materials



Tub

Polished steel tub with maintenance flap

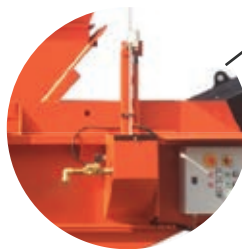

Level control

Prevents overflowing or too low water level



Electrical system

Simple and intuitive operation"

Cleaning brushes

Run free

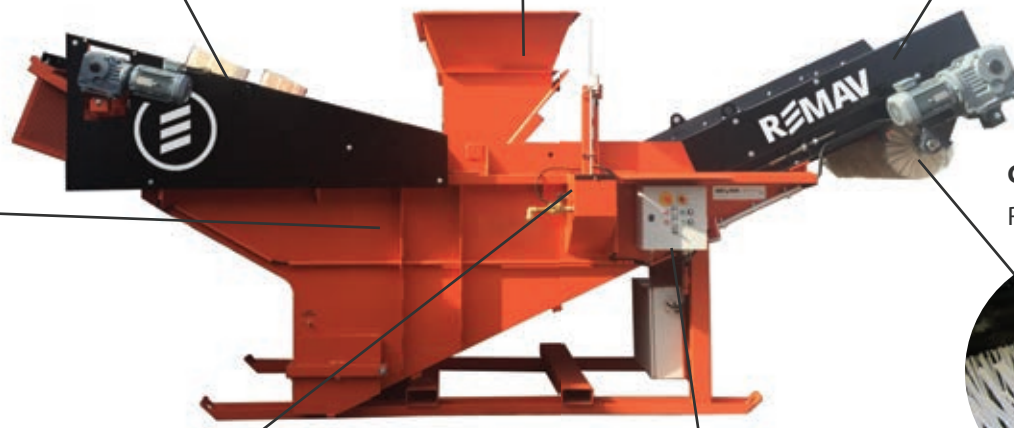
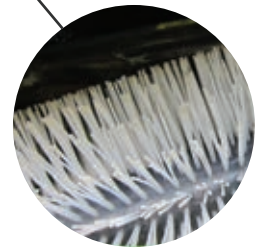

AZ18028 © copyright

REMAV GmbH
Zeppelinstr. 9
68519 Viernheim
GERMANY

Phone: +49 6204 / 30 564 37
E-mail: info@remav.de

Sales Office

Visit us at:

www.remav.de