

LETS MAKE  
ZERO-EMISSION REAL

RentalMatch.eu

**RentalMatch Green Power**  
Dealer & Partner of JMG Cranes

**Sales & Service Office**  
Ecologieweg 16  
3343 LM Hendrik-Ido-Ambacht - Netherlands  
+31 (0) 78 204 92 60  
info@rentalmatch.eu

**Gijs van de Graaf**  
+31 651855113

**Dick van de Graaf**  
+31 613214166

**Production Plant**  
Via Sito Nuovo 14  
29010 Sarmato (PC) - Italy



vca✓

**RentalMatch**  
GREEN POWER

Electric  
Pick & Carry  
Cranes



**MC 100RE (metric)**  
Max Capacity 10.000 Kg

# MC 100RE

- ✓ 360° continuous and unlimited hydraulic slewing boom
- ✓ Front and rear horizontally and vertically working
- ✓ Independent outriggers
- ✓ Carry deck slewing crane

### Options:

- Hydraulic jib with hydraulic Extension
- Non-marking tires
- Man basket
- Atex conversions
- Customized painting



### Technical features

Max Capacity kg	10.000	Front-wheels drive. 2 electric motors AC 8,5 kW 80V Insulation class H	LML Electronic safe load indicator and tilting moment limiter
	Dimensions mm	80 V - 920 Ah Autonomy 8 working hours	Automatic braking system on front and rear wheels
Front n.4 superelastic 355-65-15" Rear n.2superelastic 300-15"		Fabricated from preformed and welded steel plate	
Rear by steering axle. Steering angle -92° / +92		Boom inclination angle +74°/-7°	
		Motor driven pump 20 kW - 80 V AC.	



### Load charts

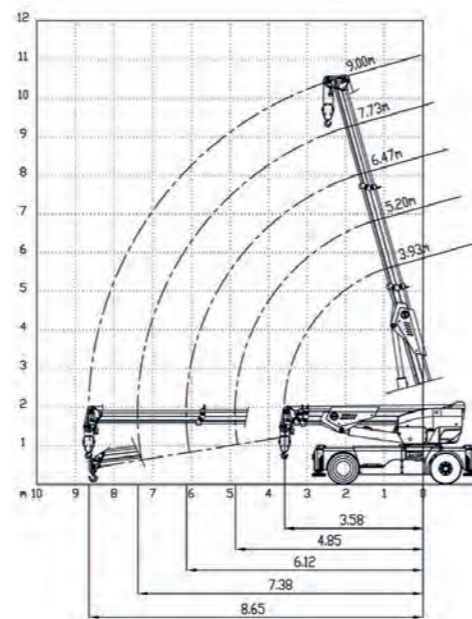

Lift height (m)	0° FRONT NO				
	3,93m	5,20m	6,47m	7,73m	9,00m
1,10m	10				
1,50m	10	10			
2,00m	10	10	10		
2,50m	10	10	10	8,5	7
3,00m	10	10	8,6	7,1	6
3,58m	7,65	7,9	7,4	6,1	5,1
4,00m		5,9	5,9	5,6	4,4
4,85m		3,9	3,9	4	3,6
5,00m			3,65	3,65	3,5
5,50m			3	3	3
6,12m			2,5	2,5	2,5
6,50m				2,25	2,25
7,00m				1,95	1,95
7,38m				1,75	1,75

Lift height (m)	0° FRONT YES				
	3,93m	5,20m	6,47m	7,73m	9,00m
1,10m	10				
1,50m	10	10			
2,00m	10	10	10		
2,50m	10	10	10	8,5	7
3,00m	10	10	8,6	7,1	6
3,58m	10	9,8	7,5	6	5,1
4,00m		8,8	6,6	5,5	4,4
4,85m		7,2	5,6	4,4	4
5,00m			5,3	4,3	3,5
5,50m			4,8	3,9	3,2
6,12m			4,4	3,7	2,8
6,50m				3,3	2,7
7,00m				3	2,5
7,38m				2,9	2,3

Lift height (m)	0° SIDE 700mm				
	3,93m	5,20m	6,47m	7,73m	9,00m
1,10m	10				
1,50m	10	10			
2,00m	10	10	10		
2,50m	10	10	10	8,5	7
3,00m	8,2	8,2	8,15	7,1	6
3,58m	5,8	5,8	5,8	5,8	5,1
4,00m		4,65	4,65	4,6	4,4
4,85m		3,35	3,35	3,3	3,3
5,00m			3,15	3,15	3,15
5,50m			2,7	2,65	2,65
6,12m			2,25	2,25	2,25
6,50m				2	2
7,00m				1,8	1,75
7,38m				1,6	1,6

Lift height (m)	0° REAR YES				
	3,93m	5,20m	6,47m	7,73m	9,00m
1,10m	10				
1,50m	10	10			
2,00m	10	10	10		
2,50m	10	10	10	8,5	7
3,00m	8,1	8,1	8,1	7,1	6
3,58m	6	6	6	6	5,1
4,00m		5	5	4,9	4,4
4,85m		3,7	3,7	3,7	3,65
5,00m			3,5	3,5	3,5
5,50m			3	3	3
6,12m			2,6	2,6	2,6
6,50m				2,35	2,35
7,00m				2,1	2,1
7,38m				1,95	1,95

### EU Standards CE

	UNI ISO 4301-1: A1
	2006/42 CE-2014/30 UE-2014/35 UE- 2000/14 e and subsequent modifications
	EN 13000:2014 ANSI/ASME B30.5-2011 and subsequent modifications

### Dimensions

